

Bent axis hydraulic motors

**M**  
Series

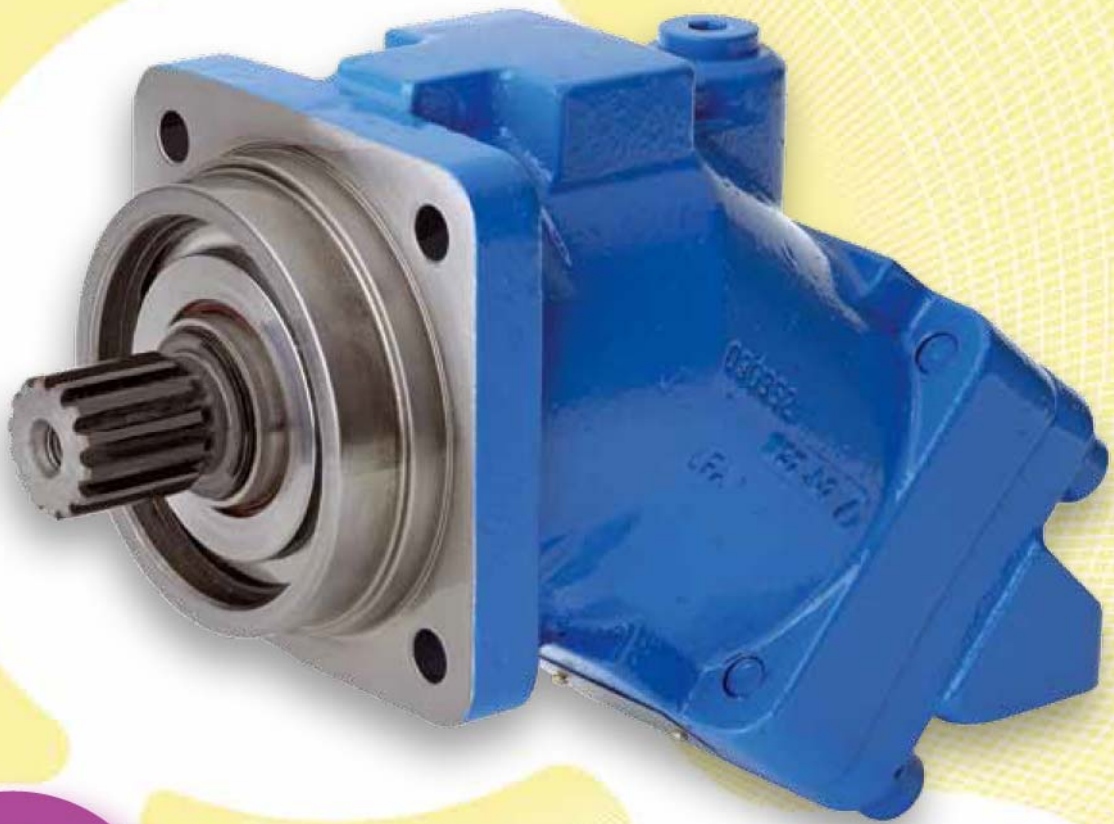

**HYDRO  
LEDUC**  
**TOHIO**<sup>®</sup>

# Contents

■ Definition and main applications of hydraulic motors, advantages of LEDUC motors .....	1
■ Operating conditions of motors .....	2
■ Determining the right motor .....	3
■ Range and characteristics .....	4
■ Efficiency curves .....	5
■ Order code system .....	6
■ Dimensions .....	7 - 17
■ Flushing valve .....	18
■ Speed sensor .....	18
■ ATEX certification .....	19
■ Installation and start-up recommendations .....	20
■ Other LEDUC product lines .....	21

## M series motors

LEDUC hydraulic motors of the M series are of bent axis design, with an angle of 40°. They combine high performance and reduced size envelope:

- global efficiency of over 90% (guaranteed in most applications);
- suitable for use at operating speeds between 50 and 8,800 rpm;
- optimized weight and size.

Available in displacements from 12cc to 125cc, M motors are suitable for all the main fixed and mobile applications. They are designed for use in either closed or open loop systems. To ensure the best service life from your motors, please take care to follow the installation and start-up recommendations (see pages 2 and 20).

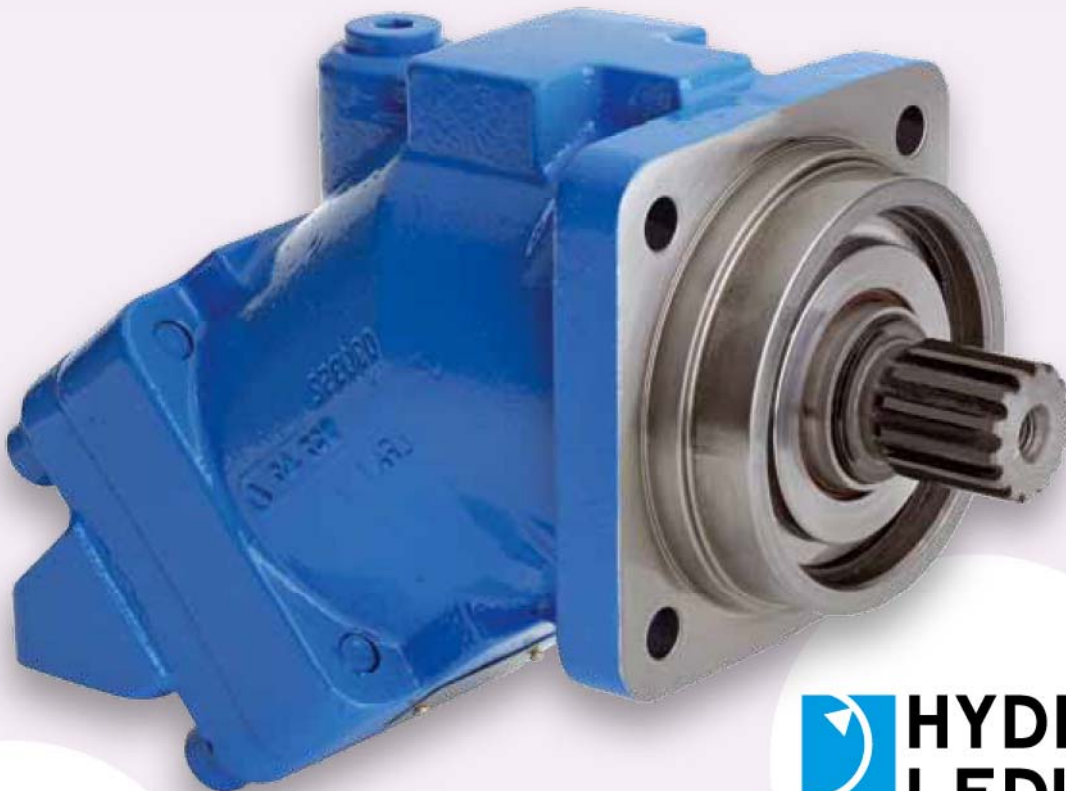

HYDRO LEDUC also manufactures a range of semi-integrated (plug-in) motors: the MSI series. Literature on request or on our website : [www.hydroleduc.com](http://www.hydroleduc.com)

 **HYDRO  
LEDUC**

**HYDRO LEDUC**  
Head Office & Factory  
BP 9  
F-54122 AZERAILLES (FRANCE)  
Tél. +33 (0)3 83 76 77 40  
Fax +33 (0)3 83 75 21 58



# Advantages of M series motors

## ■ Definition of function

Hydraulic motors transform hydraulic flow into rotating speed and hydraulic pressure into mechanical torque.

Motor rotating speed is proportional to the flow which is supplied to it.

Torque produced is proportional to the hydraulic pressure the motor receives.

## ■ Main applications of hydraulic motors

Typical applications are those requiring high torque within a small size.

The hydraulic motor is essential for rotations where:

- mechanical solutions are complex or even impossible,
- electrical or pneumatic power sources are not available,
- environments are dangerous (i.e. risk of explosion or extreme temperatures).

## ■ Advantages of LEDUC motors

All structural components are made from similar materials resulting in consistent thermal expansion and exceptional reliability.

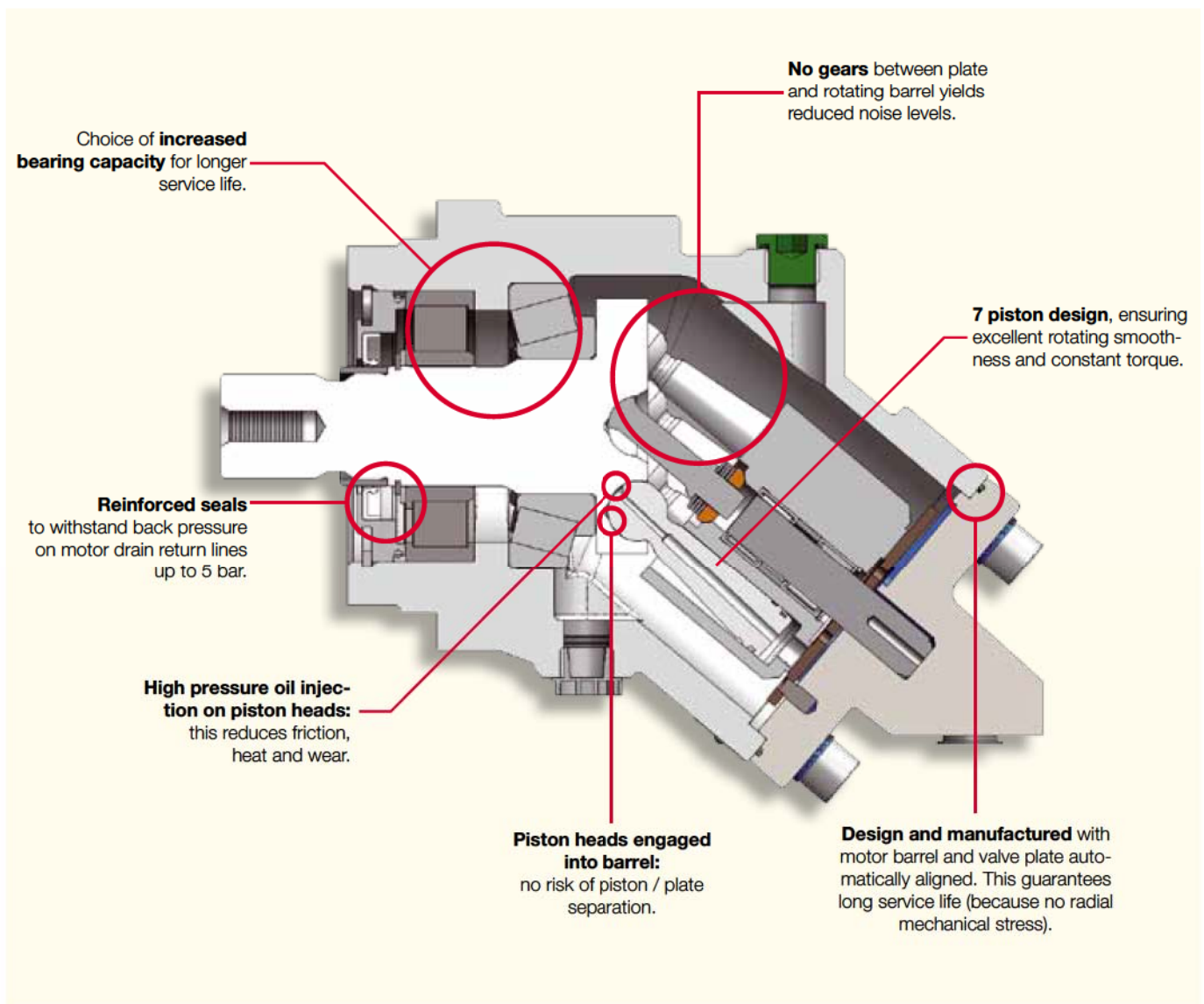

# Operating conditions of M series motors

## Hydraulic fluid

LEDUC motors are designed to be powered with mineral based hydraulic fluid. Using other fluids is possible but may require a modified motor. Please contact us with details of fluid.

Recommended viscosity:

- Ideally : between 15 and 200 cSt;
- Maximum range: between 5 and 1600 cSt.

## Filtration of hydraulic fluid

The service life of the motors depends greatly on the quality and the cleanliness of the hydraulic fluid.

We recommend minimum cleanliness as follows:

- NAS 1638 class 9
- SAE class 6
- ISO/DIS 4406 class 18/15

## Direction of rotation

The motors rotate clockwise or counter-clockwise depending on the direction of hydraulic flow entering the motor.

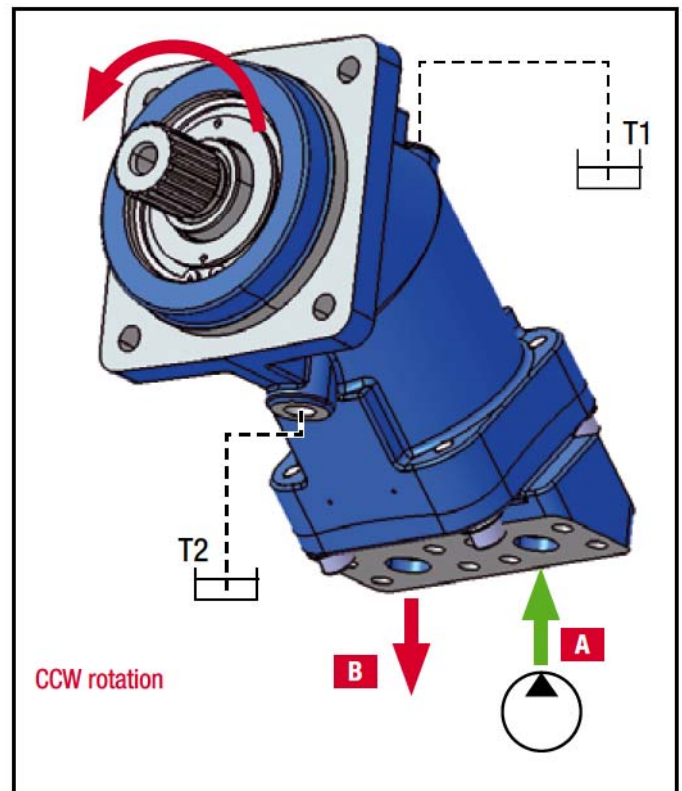
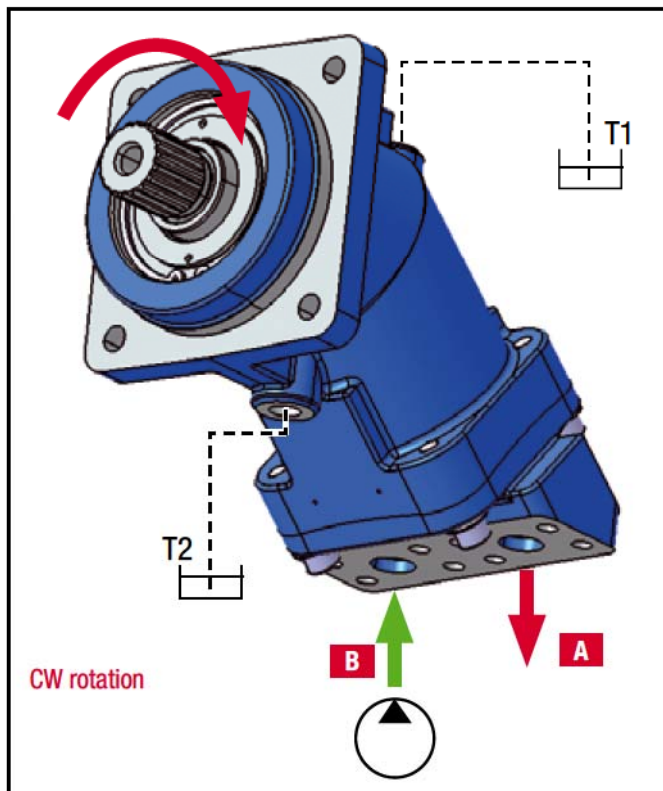

## Drain pressure

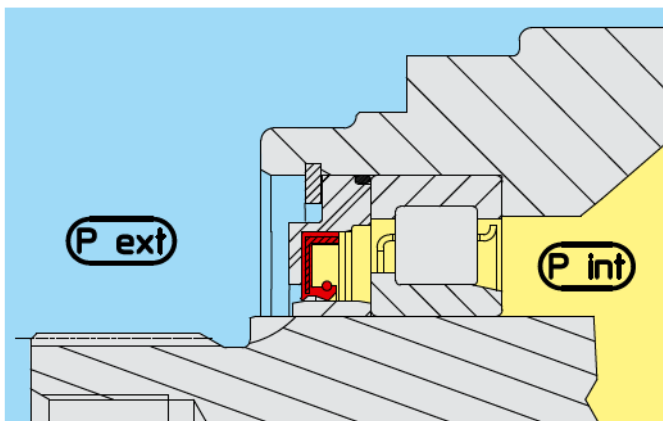

It is essential to drain the motor, T1 or T2, to avoid excessive pressures on the shaft seal.

Maximum acceptable internal pressure depends on motor rotating speed.

However, following these guidelines will avoid problems during operation:

- maximum internal pressure (**P int**) regardless of rotating speed (continuous): 4 bar (60psi);
- maximum internal pressure (**P int**) regardless of rotating speed (peak): 5.5 bar (80psi);
- minimum pressure in the motor housing: must be greater than ambient (external) pressure (**P ext**).

# Determination M series motors

## How to determine the correct motor for your application

Calculations using usual mechanical units:

- N = rotating speed in rpm
- C = torque in N.m
- P = pressure supplied by the generator (hydraulic pump), in bar
- $\Delta P$  = pressure difference between A and B, in bar
- Disp. = displacement in cc
- Q = flow in litres per minute
- $\eta$  = efficiency (%)

### 1. Torque supplied by the hydraulic motor

$$\text{Theoretical torque} = \frac{\text{Disp.} \times \Delta P}{20 \pi} = C_{th}$$

$$\text{Torque } C = C_{th} \times \eta_{motor}$$

For example: a 50cc motor with a  $\Delta P$  of 250 bar will supply a theoretical torque of : 200 N.m.  
Average global efficiency of the motor is 90%, actual torque is thus: 180 N.m

### 2. Rotating speed of the motor

The rotating speed of the hydraulic motor depends on the flow Q which goes through it, and on the displacement of the motor.

$$N = \frac{Q}{\text{Disp.}} \times 1000$$



test bench for motors

## Example

- ① Motor
- ② Variable displacement pump
- ③ Pressure relief valve
- ④ Valve
- ⑤ Hydraulic motor
- ⑥ Winch and load

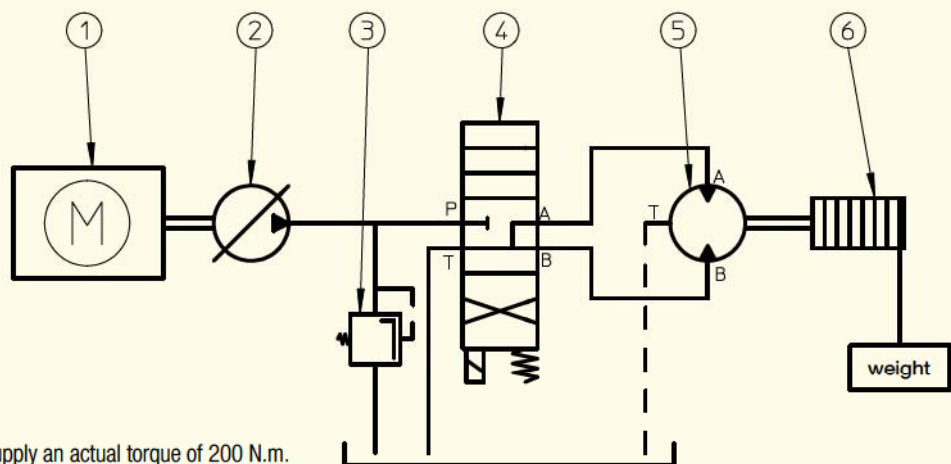

The receiving organ (winch) ⑥ needs to rotate at  $N = 400$  rpm and supply an actual torque of 200 N.m.

The hydraulic pump ① is capable of operating at pressure P up to 350 bar.

1. Calculating the displacement of the hydraulic motor:

$$C_{th} = \frac{\text{Disp.} \times \Delta P}{20 \pi} \text{ thus Disp. } \mathbf{Cy = 35.9 \text{ cc}}$$

▶ In the LEDUC range, choose a motor with a displacement of **32 cc** or **41 cc**.

2. Calculating the flow Q which the pump needs to supply:

$$N = \frac{Q}{\text{Disp.}} \times 1000 \text{ thus } \mathbf{Q = 14.36 \text{ l/min}}$$

Corresponding flow :  
- for **32 cc** motor,  $Q = 12.8 \text{ l/min}$   
- for **41 cc** motor,  $Q = 16.4 \text{ l/min}$



# Range and characteristics M series motors



## Characteristics of the M series motors

M series motors are suitable for intensive long duty requirements. Designed for both mobile and industrial installations.

Typical applications are:

- vehicle transmissions;
- high power crushers;
- forestry equipment;
- heavy duty winches...

These motors are built to suit all applications to ISO standard 3019/2.

Motor model	Displacement (cc)	continuous max. speed <sup>(1)</sup> (rpm)	Intermittent max. speed <sup>(1)</sup> (rpm)	Max. flow absorbed (l/mn)	Torque bar (m.N/bar)	Torque at 350 bar (m.N)	Motor max./min. temperature* (°C)	Max. allowable pressure continuous / peak (bar)	weight (kg)
M 12	12	8000	8800	96	0.19	66	-25 / 110	400 / 450	5.5
M 18	18	8000	8800	144	0.28	98	-25 / 110	400 / 450	5.5
M 25	25	6300	6900	158	0.4	140	-25 / 110	400 / 450	11.5
M 32	32	6300	6900	202	0.5	175	-25 / 110	400 / 450	11.5
M 41	41	5600	6200	230	0.65	227	-25 / 110	400 / 450	11.5
M 45	45	5000	5500	225	0.72	250	-25 / 110	400 / 450	18
M 50	50.3	5000	5500	252	0.8	280	-25 / 110	400 / 450	18
M 63	63	5000	5500	315	1	350	-25 / 110	400 / 450	18
M 80	80.4	4500	5000	362	1.27	445	-25 / 110	400 / 450	23
M 90	90	4500	5000	378	1.42	497	-25 / 110	400 / 450	23
M 108	108.3	4000	4400	435	1.7	595	-25 / 110	400 / 450	23
M 108 R	108.3	3400	4500	367	1.7	595	-25 / 110	400 / 450	30
M 125	125	3400	4500	426	2	695	-25 / 110	400 / 450	30

\* for wider extreme temperatures, please contact us.

(1) for higher speeds, please contact us.

For special fluids, please contact us.

## Acceptable forces applied to motor shaft

**Fr** : radial force measured at mid point of length of shaft.

**Fa** : axial force which tends to push the shaft inwards.

Motor model		M 12	M 18	M 25	M 32	M 41	M 45	M 50	M 63	M 80	M 90	M 108	M 108 R	M 125
<b>Fr</b>	N	2800	4000	6000	6500	7000	6500	7500	9000	10500	6700	7000	12500	14500
<b>Fa</b>	N/bar*	15	20	27	30	40	40	40	50	60	67	80	80	86

\* differential pressure between A and B.

For other forces, please contact us.

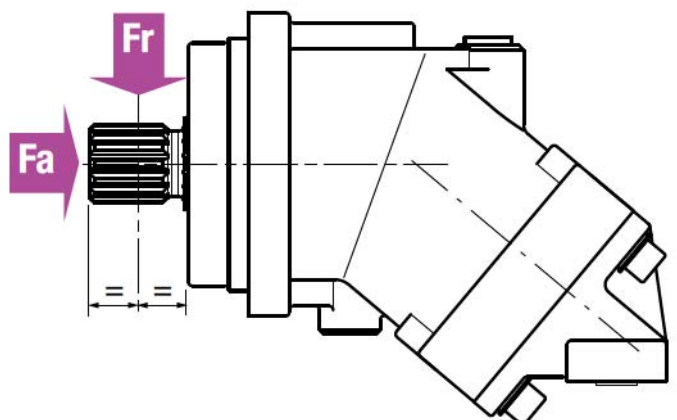

# Efficiency M series motors

## Efficiency of motors $f(\text{displacement})$

N of motor = 1000 rpm  
ISO46 fluid at 25°C

### M 12 - 18

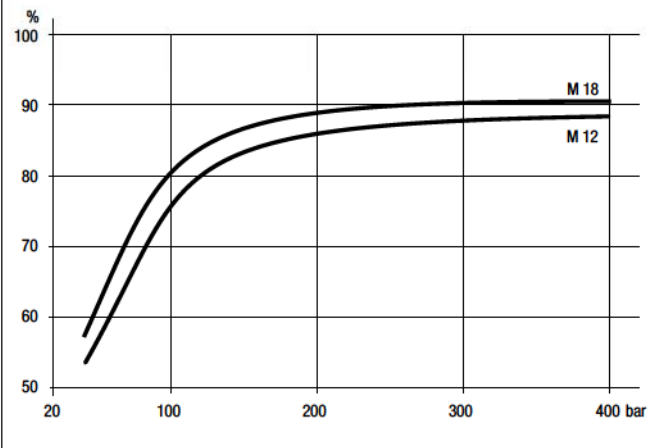

### M 25

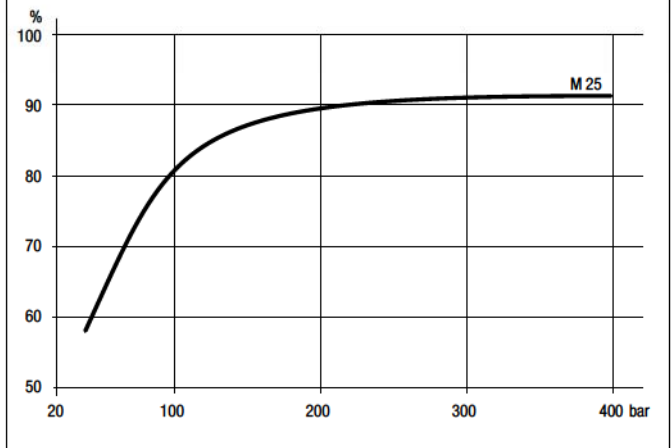

### M 32 - 41

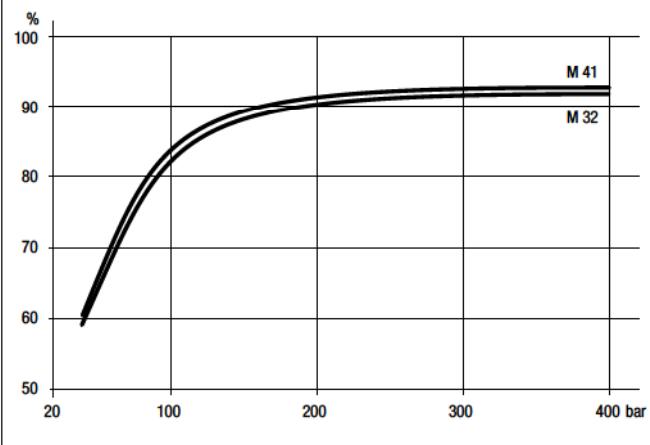

### M 45 - 50 - 63

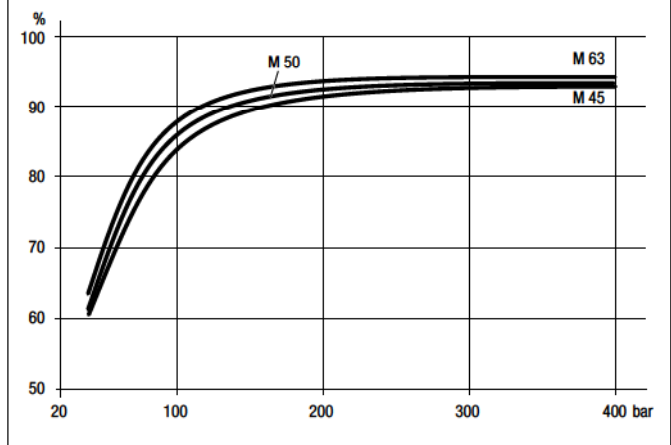

### M 80 - 90 - 108

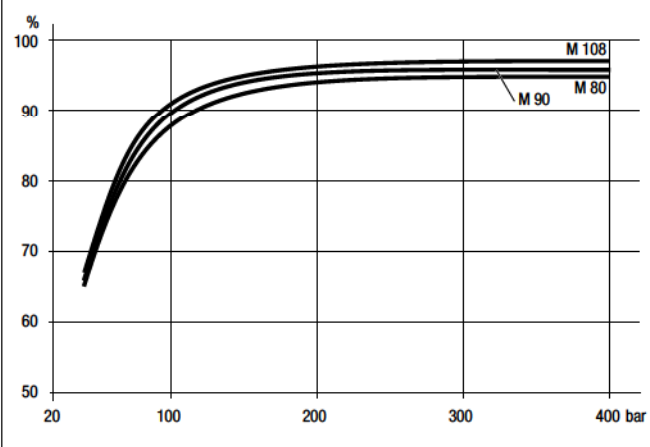

### M 108 R - 125

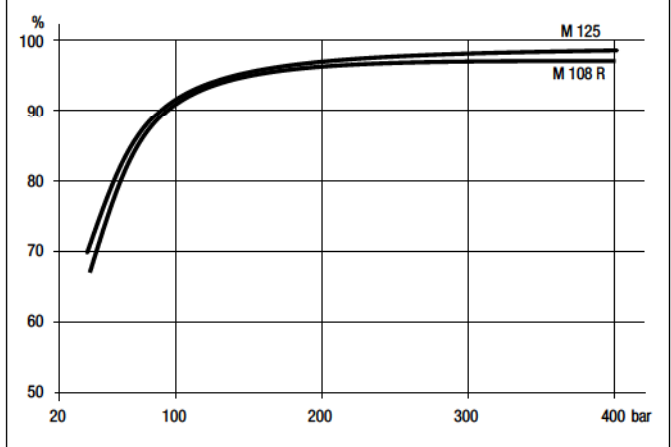

# Order code system M series motors

## Order code system for M type motor

<b>M</b>	...	<b>A</b>	..	..	<b>M2</b>	.	.	..	..
<b>01</b>	<b>02</b>	<b>03</b>	<b>04</b>	<b>05</b>	<b>06</b>	<b>07</b>	<b>08</b>	<b>09</b>	<b>10</b>

To obtain the code for your motor, complete the different parameters 02, 04, 05, 07, 08, 09 and 10 in the table on the left, according to the options you require (see table below).

<b>Motor</b>															
01	Motor													<b>M</b>	
<b>Displacement</b>															
02	12 18 25 32 41 45 50 63 80 90 108 108R 125														
<b>Mounting flange</b>															
03	4 bolts ISO 3019-2													<b>A</b>	
<b>Shaft end</b>															
04	DIN 5480 splined	W25	W25	W25	W30	W30	W30	W30	W30	W40	W40	W40	W45	W45	<b>W1</b>
		W20	-	W30	W25	-	W35	W35	W35	W35	-	-	W40	W40	<b>W2</b>
	DIN 6885 keyed	∅ 25	∅ 25	∅ 25	∅ 30	∅ 30	∅ 30	∅ 30	∅ 30	∅ 40	∅ 40	∅ 40	∅ 45	∅ 45	<b>D1</b>
		∅ 20	-	∅ 30	∅ 25	-	∅ 35	∅ 35	∅ 35	-	-	-	∅ 40	-	<b>D2</b>
<b>Inlet ports A and B</b>															
05	SAE flange ports	bottom	0	-	-	-	•	•	•	•	•	•	•	•	<b>L0</b>
		rear	0	-	-	•	•	•	•	•	•	•	•	•	<b>M0</b>
		side	0	-	-	•	•	•	•	•	•	•	•	•	<b>N0</b>
	Threaded	side	1	-	-	•	•	•	•	•	•	•	•	•	<b>N1</b>
			0	•	•	•	•	•	•	•	•	•	-	-	<b>Q0</b>
		rear	1	-	-	•	•	•	•	•	•	•	-	-	<b>Q1</b>
0	•	•	•	•	•	•	•	•	•	•	-	-	<b>P0</b>		
<b>Drain ports T1 and T2</b>															
06	-	2 2 2 2 2 2 2 2 2 2 2 2 2 2												<b>M2</b>	
<b>Suitable for use of speed sensor</b>															
07	yes														<b>1</b>
	no														<b>0</b>
<b>Speed sensor</b>															
08	yes														<b>1</b>
	no														<b>0</b>
<b>Valves</b>															
09	without														<b>SV</b>
	with flushing valve														<b>VB</b>
<b>Low temperature option</b>															
10	yes (NBR)														<b>N</b>
	no (FKM)														<b>F</b>

Suitability for valves:  
 - no ..... 0  
 - compatible with flushing valve ..... 1



## Dimensions

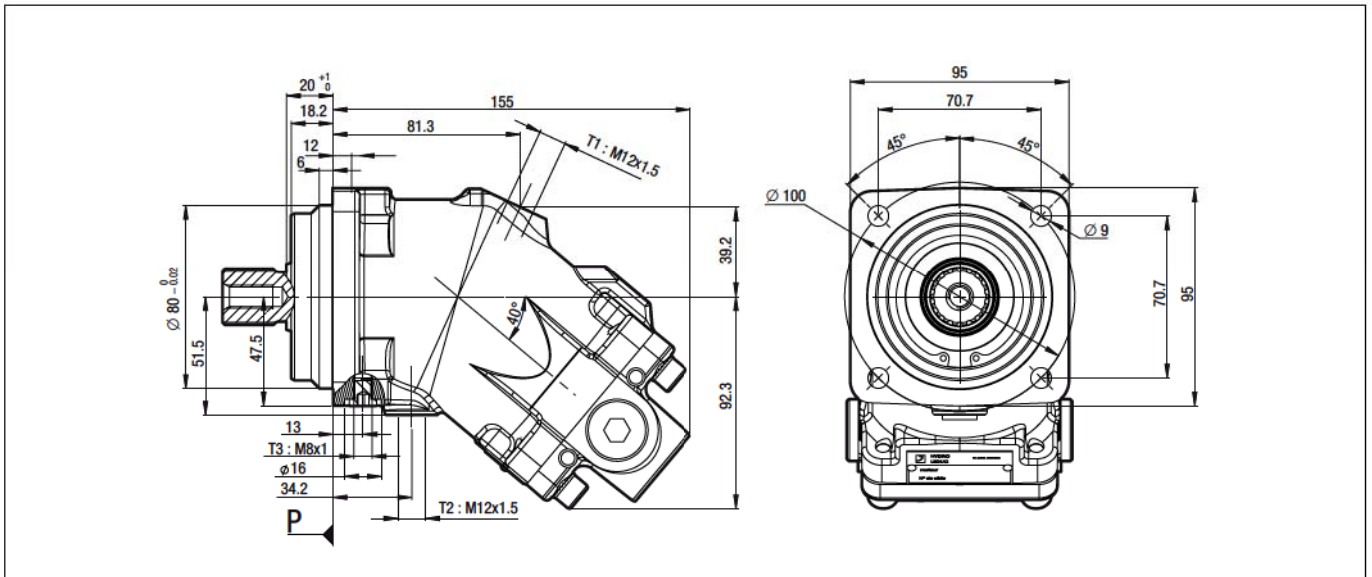

## Shaft end

**W1** Splined shaft DIN 5480  
W 25 x 1.25 x 30 x 18 x 9 g

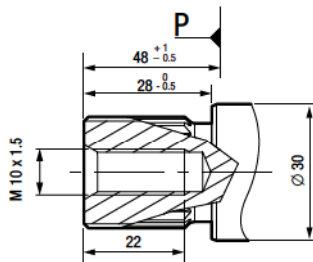

**D1** Cylindrical keyed shaft  $\varnothing$  25 DIN 6885  
AS 8 x 7 x 32

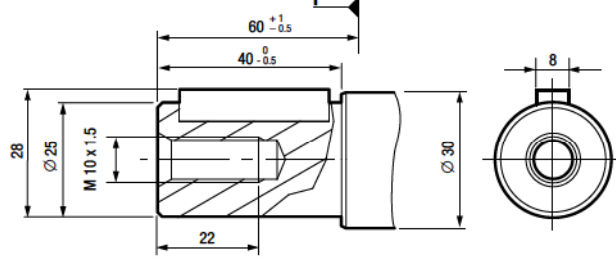

**W2** Splined shaft DIN 5480  
W 20 x 1,25 x 30 x 14 x 9 g  
For M 12 only.

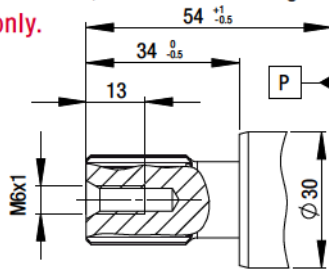

**D2** Cylindrical keyed shaft  $\varnothing$  20 DIN 6885  
AS 6 x 6 x 32  
For M 12 only.

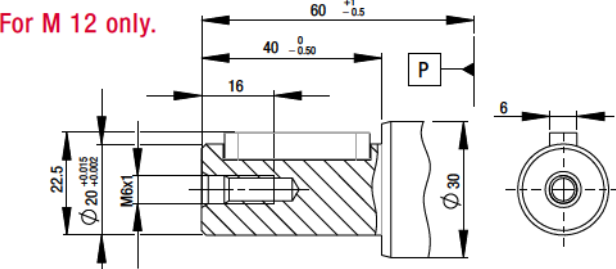

## Inlet ports

**Q0** Side threaded ports A et B

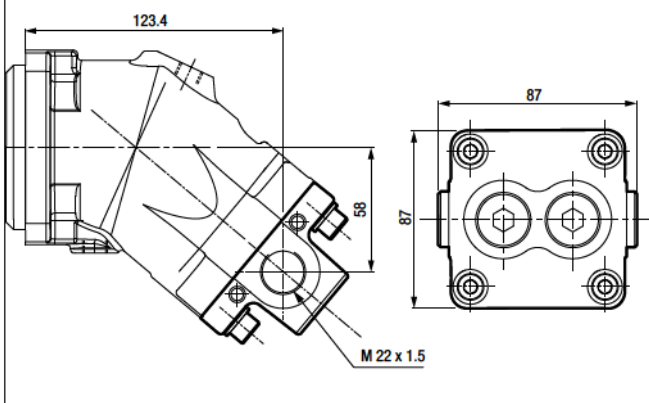

**P0** Rear threaded ports A and B

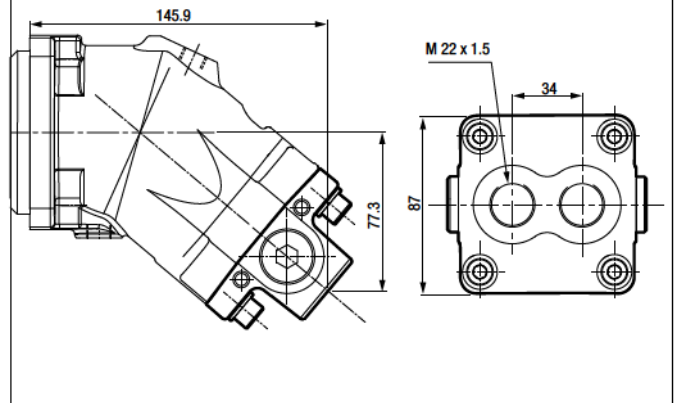

## Dimensions

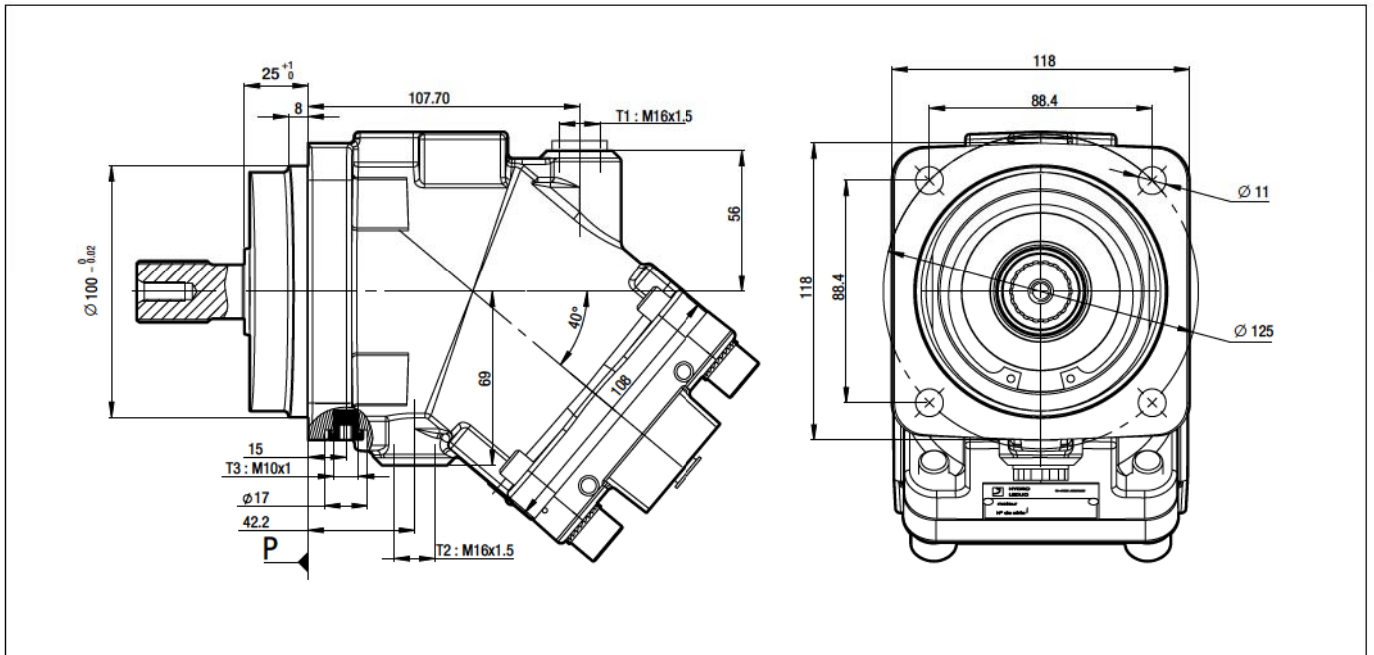

## Shaft end

**W1** Splined shaft DIN 5480  
W 25 x 1.25 x 30 x 18 x 9 g

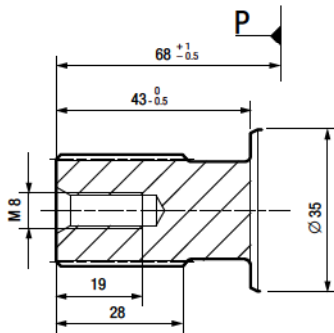

**W2** Splined shaft DIN 5480  
W 30 x 2 x 30 x 14 x 9 g

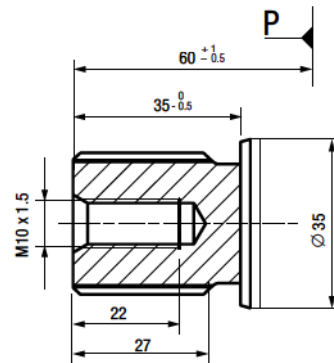

**D1** Cylindrical keyed shaft  $\varnothing 25$   
DIN 6885 AS 8 x 7 x 40

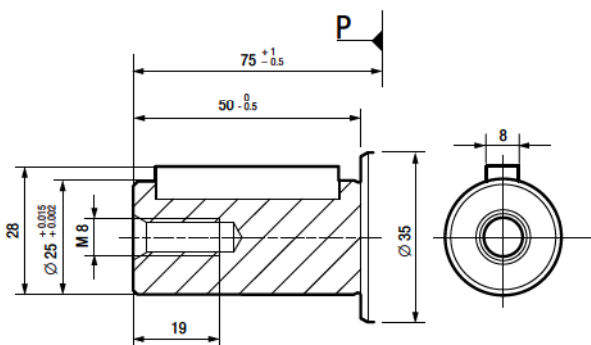

**D2** Cylindrical keyed shaft  $\varnothing 30$   
DIN 6885 AS 8 x 7 x 40

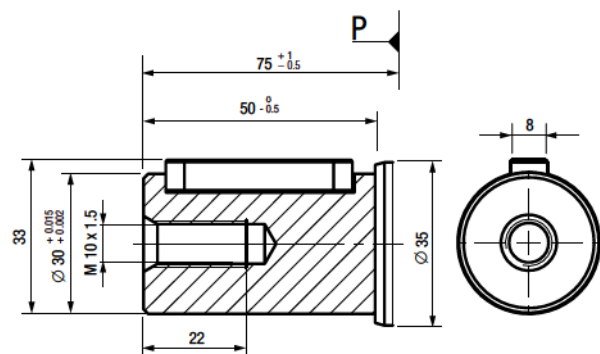

## Inlet ports

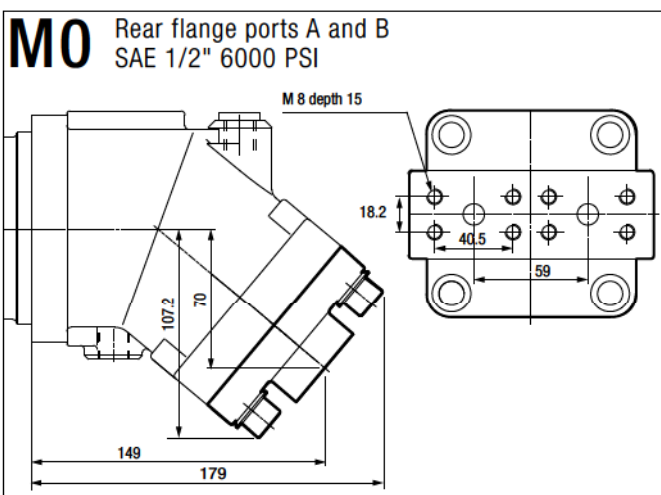
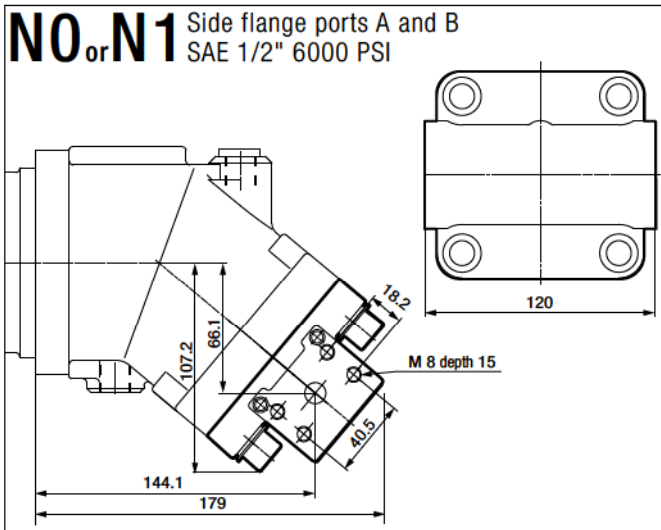
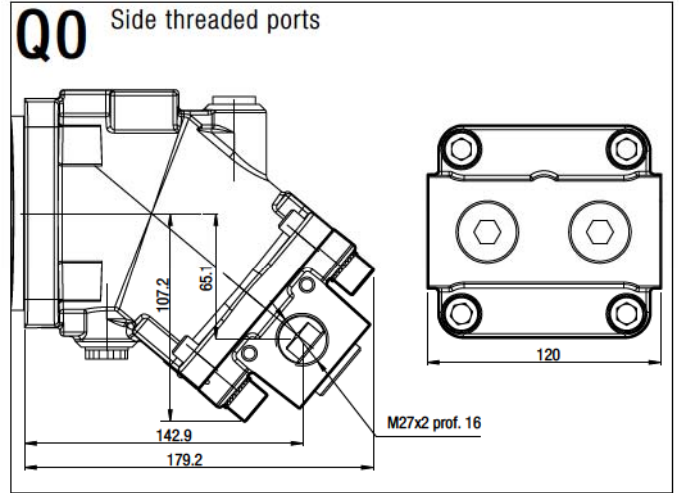
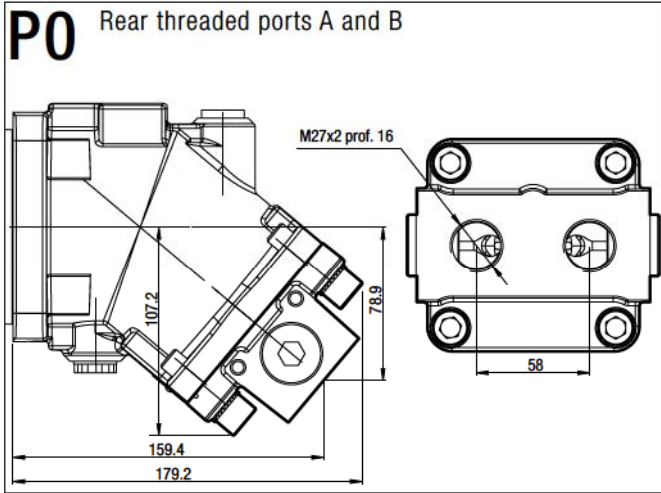



## Dimensions

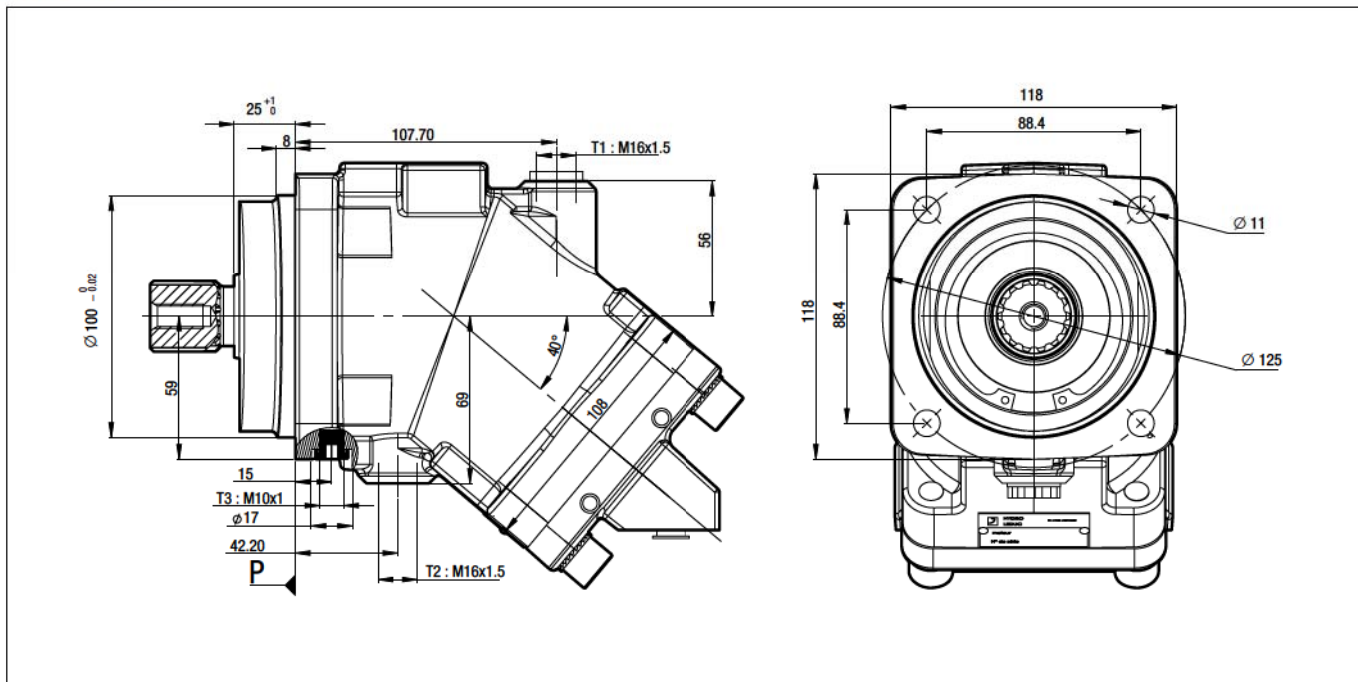

## Shaft end

**W1** Splined shaft DIN 5480  
W 30 x 2 x 30 x 14 x 9 g

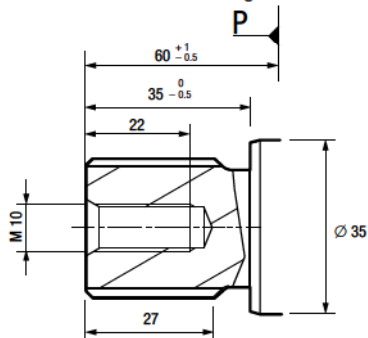

**W2** Splined shaft DIN 5480  
W 25 x 1.25 x 30 x 18 x 9 g - For M 32 only.

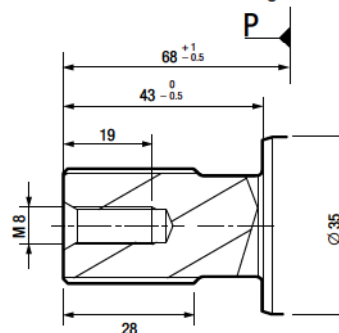

**D1** Cylindrical keyed shaft  $\varnothing 30$  DIN 6685  
AS 8 x 7 x 40

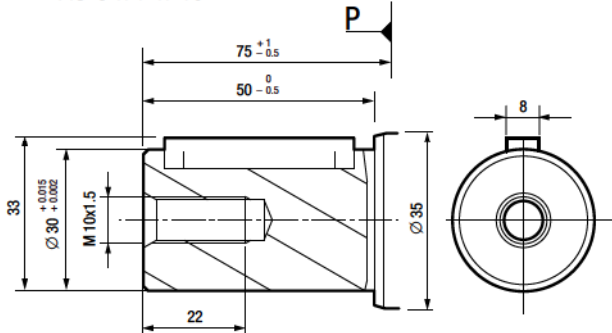

**D2** Cylindrical keyed shaft  $\varnothing 25$  DIN 6685  
AS 8 x 7 x 40 - For M 32 only.

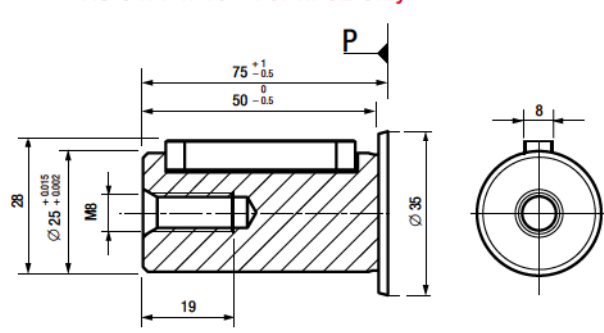

## Inlet ports

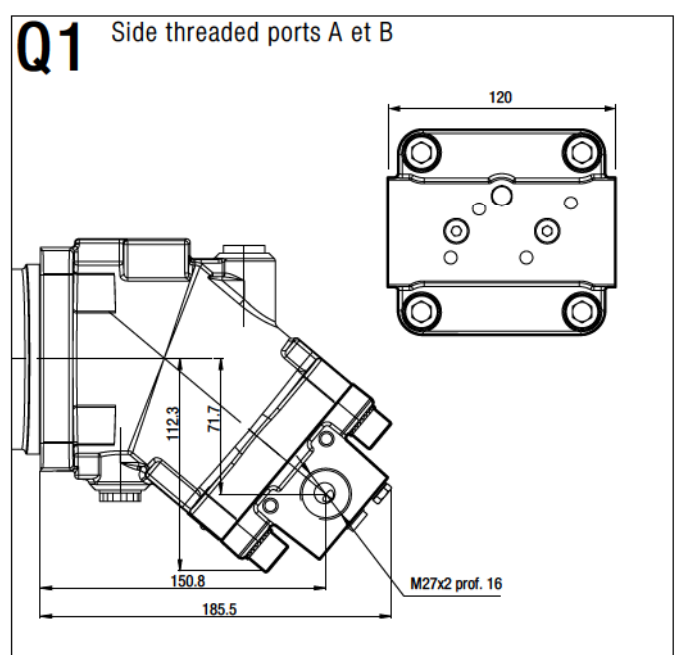
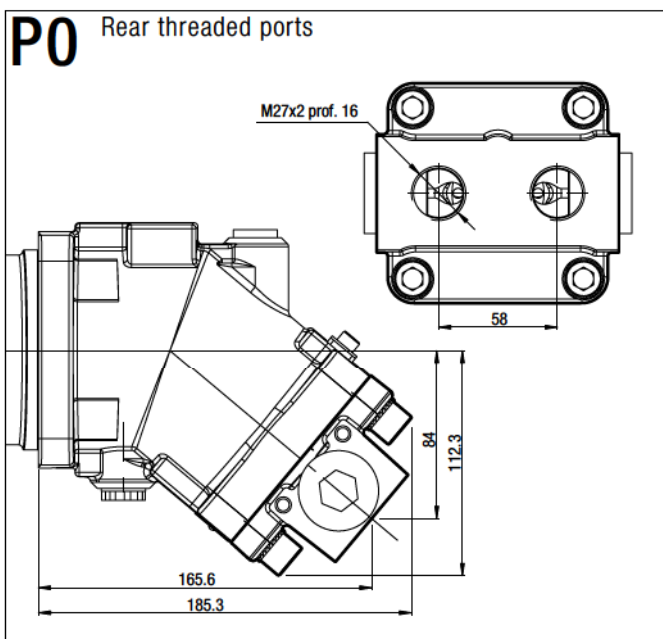
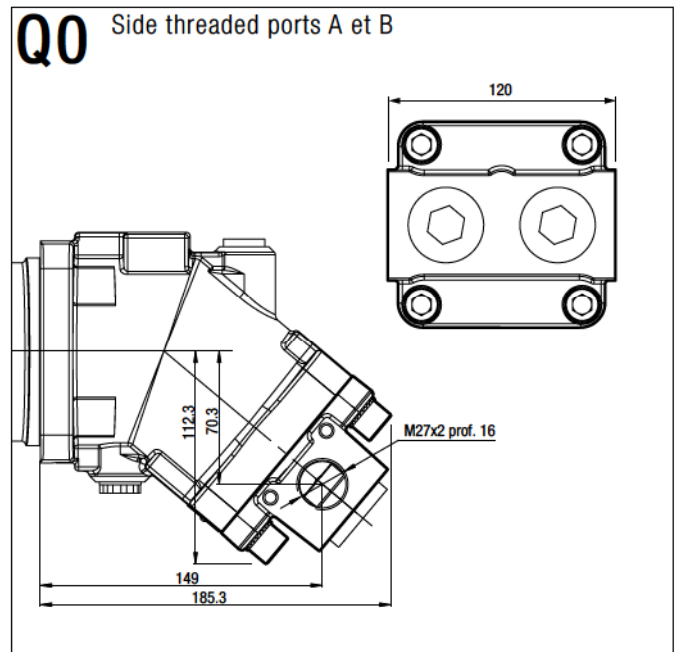
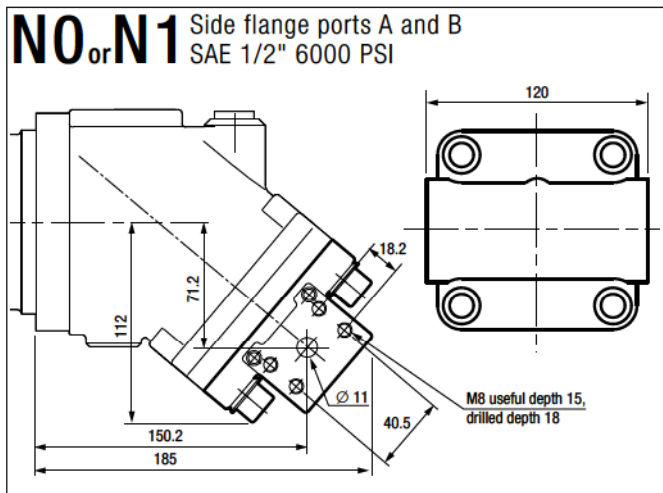
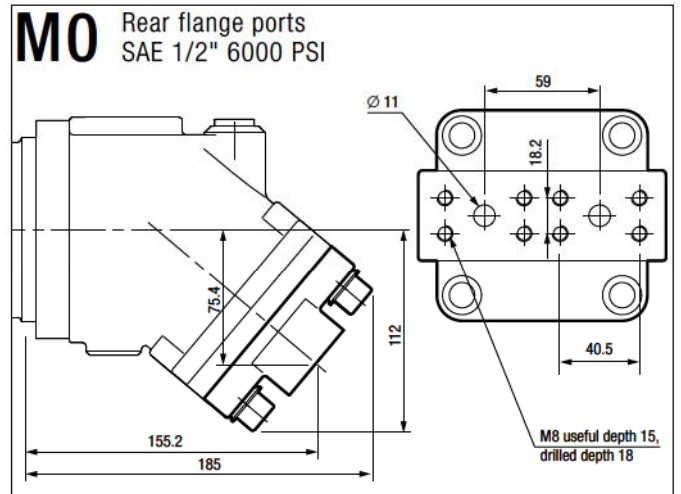
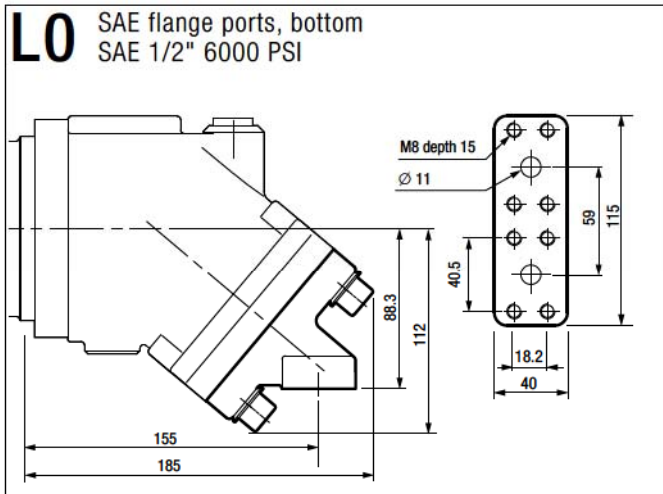

## Dimensions

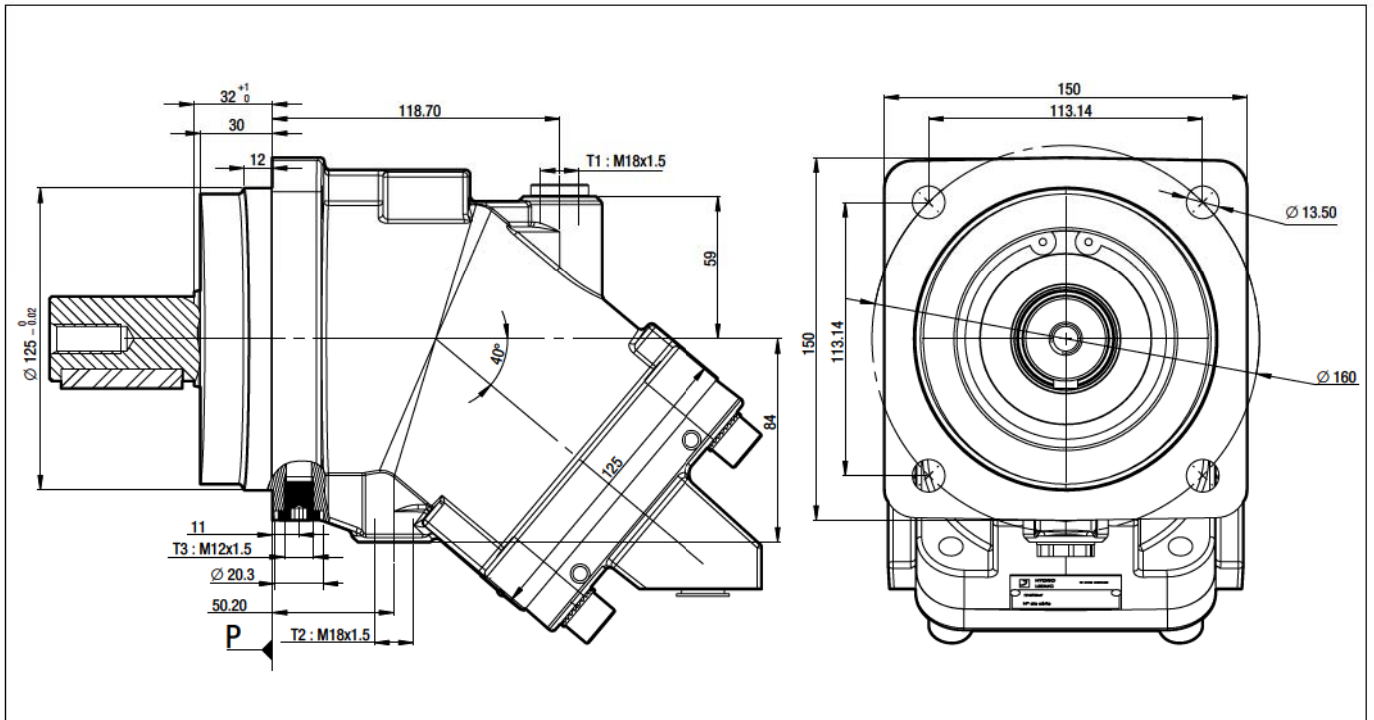

## Shaft end

12

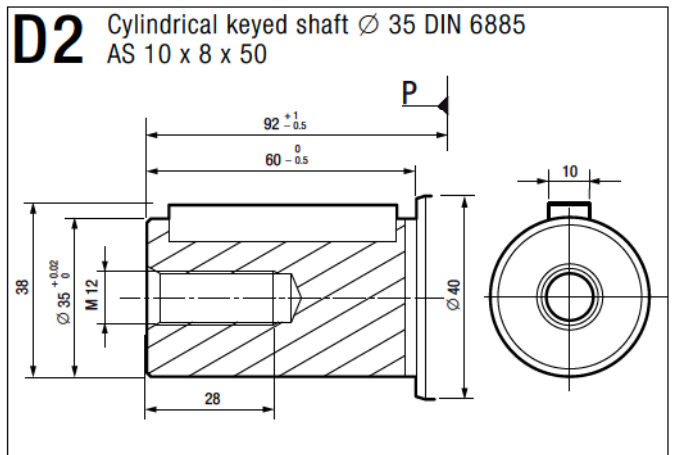
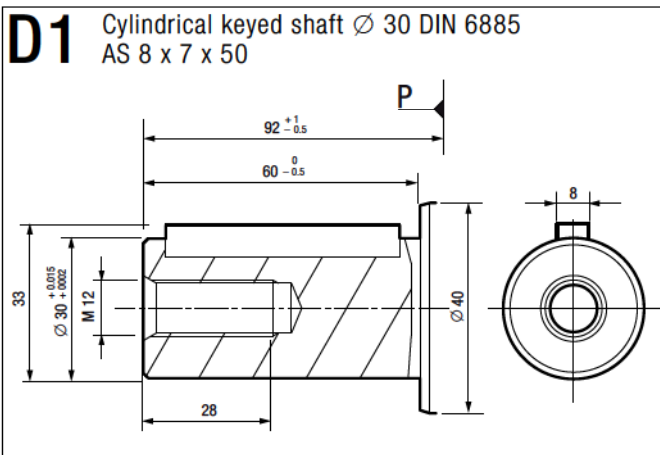
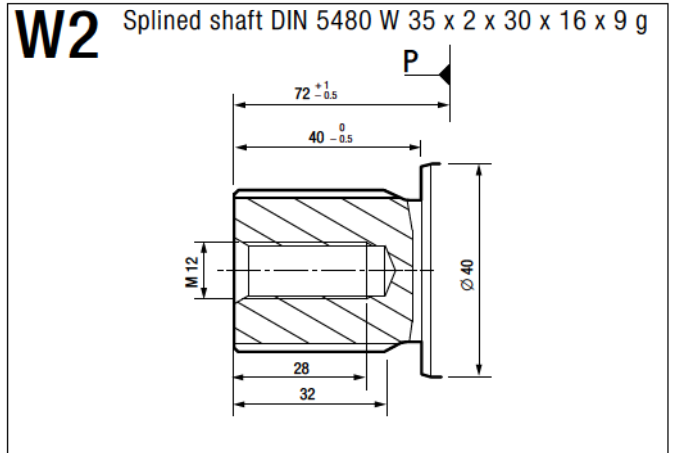
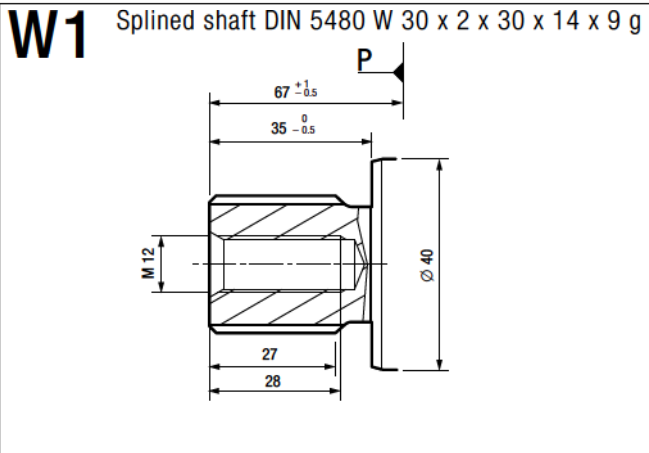



## Inlet ports

**L0** SAE flange ports, bottom  
SAE 3/4" 6000 PSI

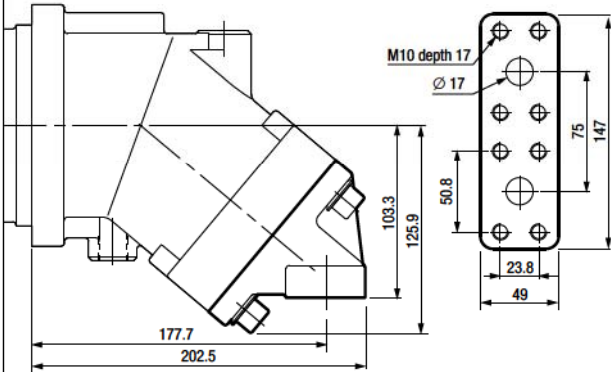

**M0** SAE flange ports, rear  
SAE 3/4" 6000 PSI

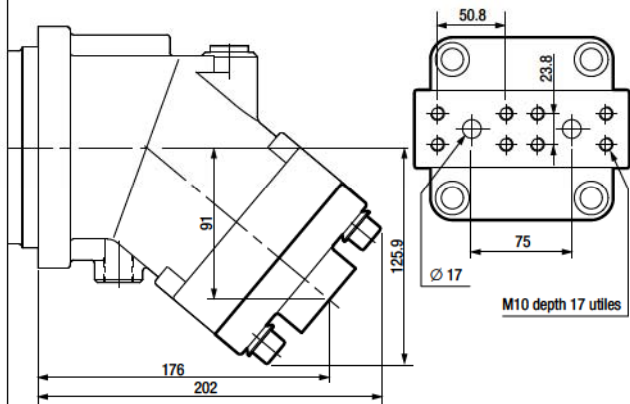

**N0 or N1** SAE flange ports, side A and B  
SAE 3/4" 6000 PSI

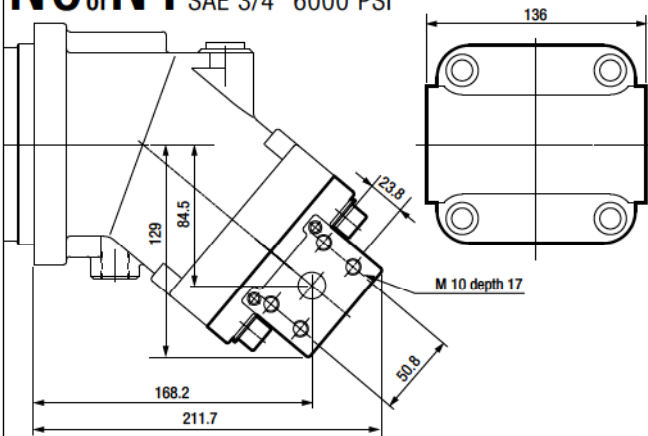

**P0** Rear threaded ports

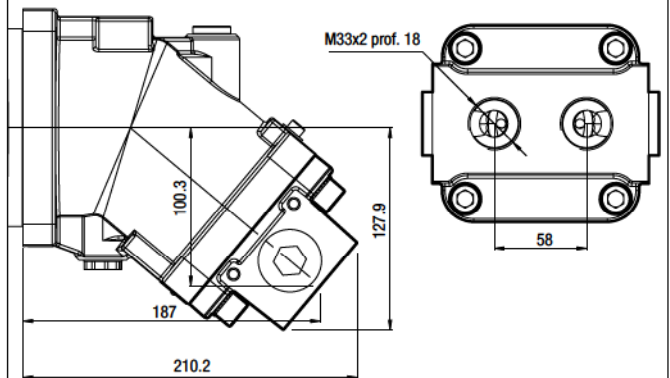

**Q0** Side threaded ports A and B

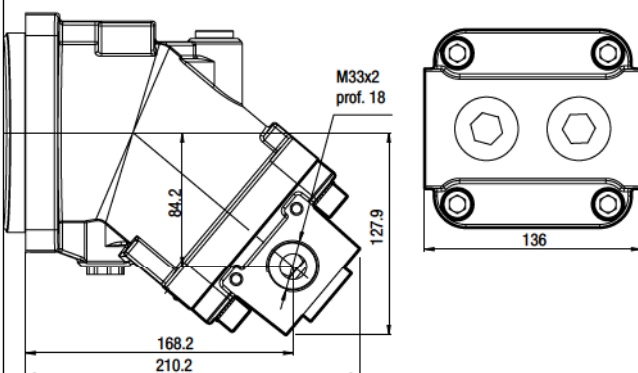

**Q1** Side threaded ports A and B

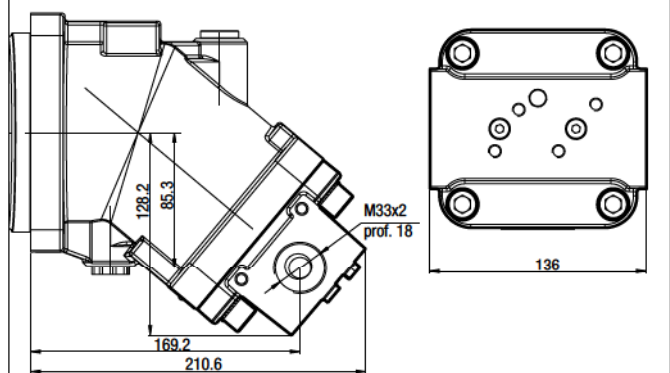



Inlet ports

**L0** SAE flange ports, bottom  
SAE 1" 6000 PSI

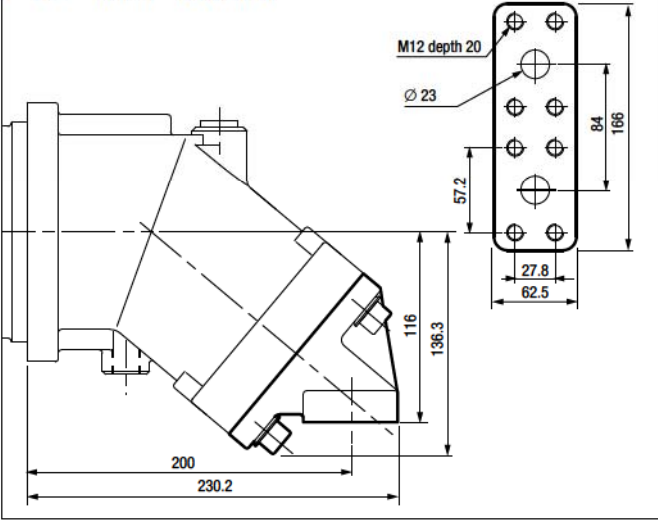

**P0** Rear threaded ports

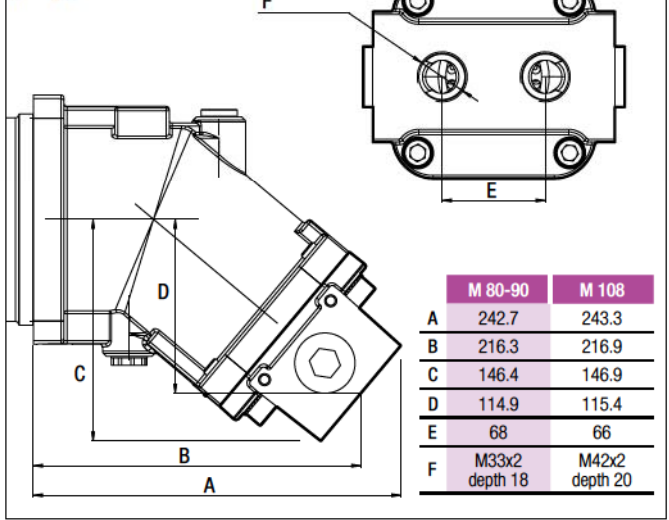

**M0** SAE flange ports, rear  
SAE 1" 6000 PSI

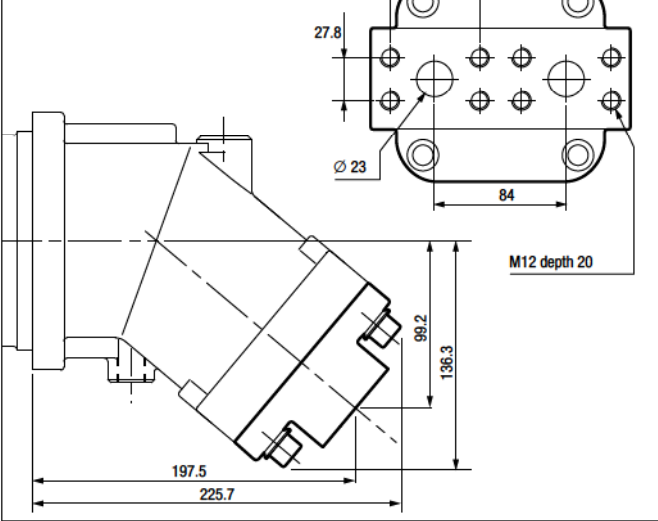

**Q0** Side threaded ports

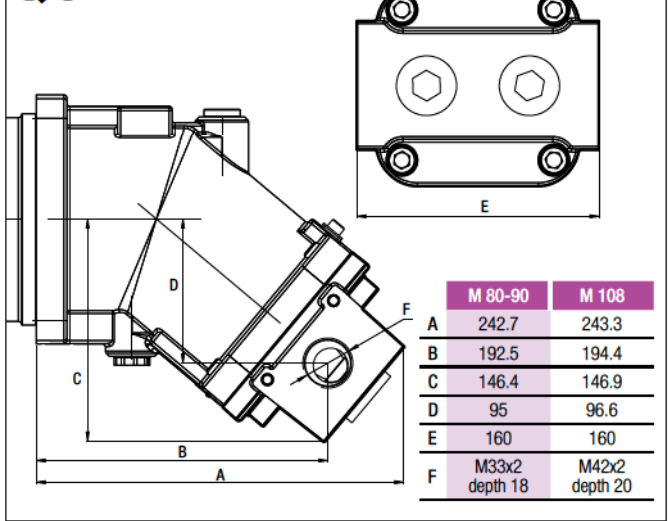

**N0 or N1** SAE flange ports, side  
SAE 1" 6000 PSI

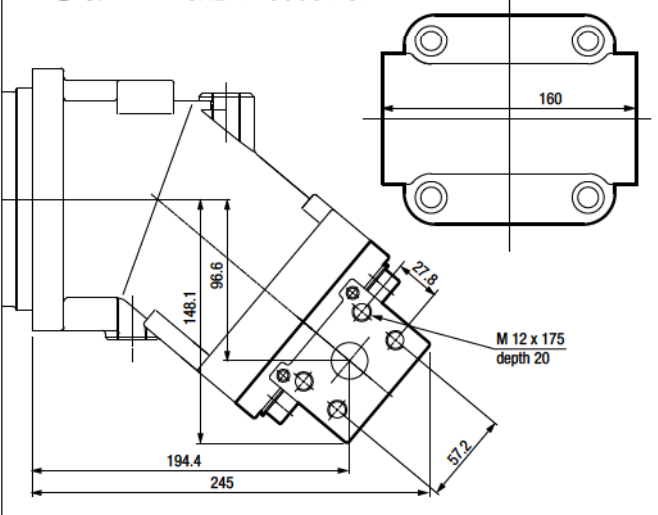

**Q1** Side threaded ports

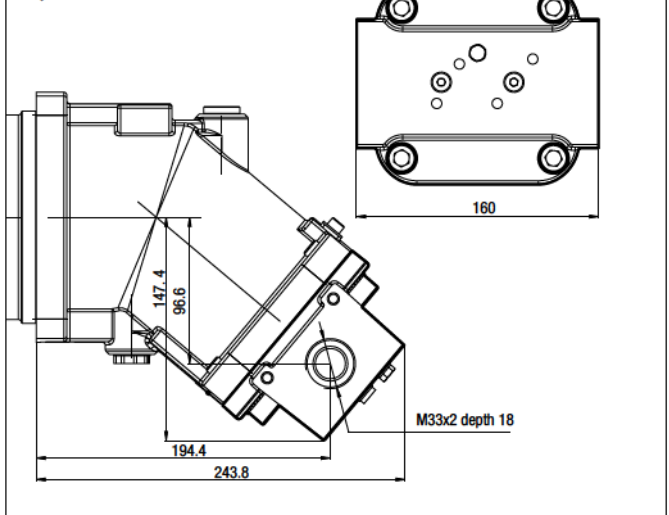



## Dimensions

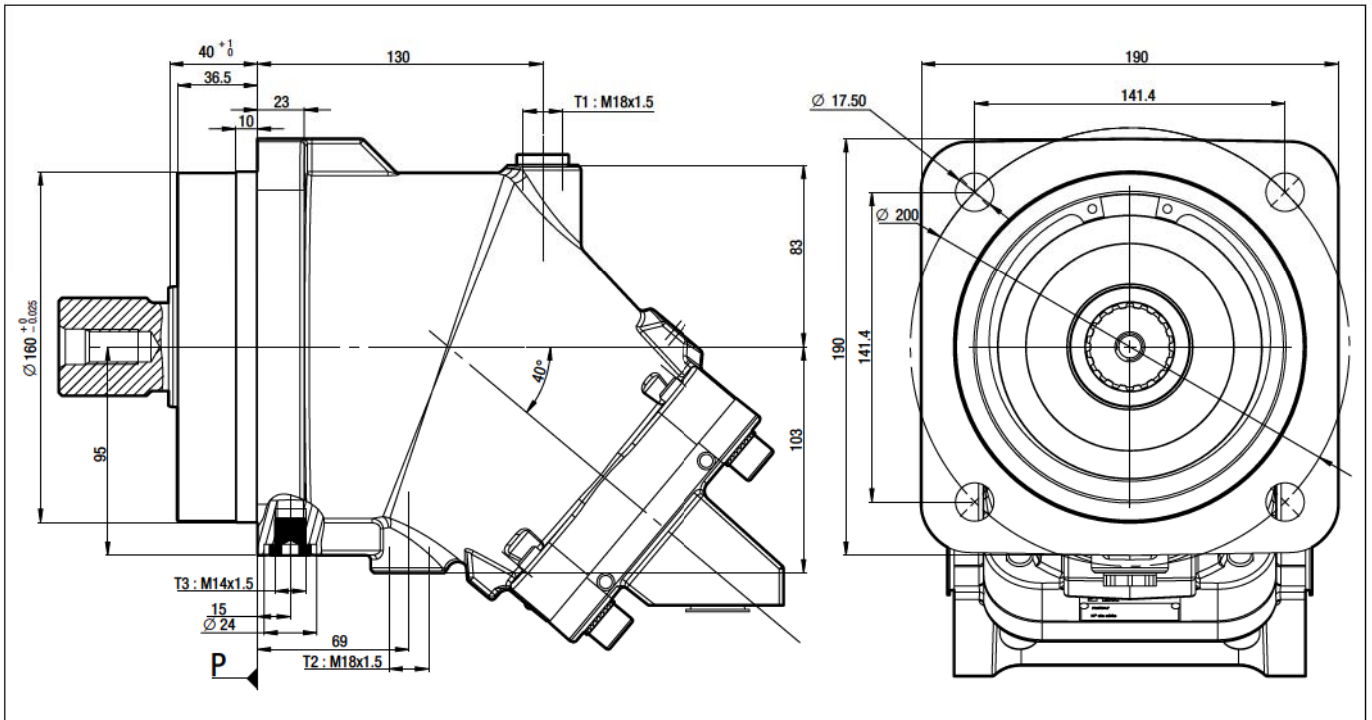

## Bout d'arbre

16

**W1** Splined shaft DIN 5480  
W 45 x 2 x 30 x 21 x 9 g

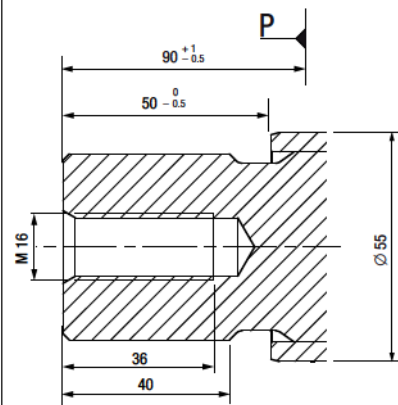

**D1** Cylindrical keyed shaft  $\varnothing 45$  DIN 6885  
AS 14 x 9 x 63

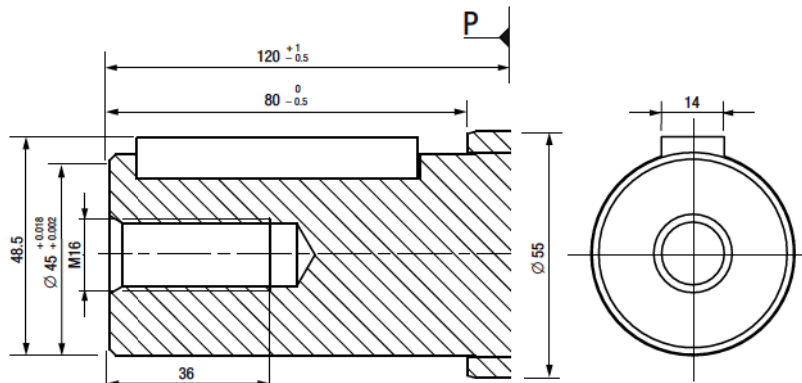

**W2** Splined shaft DIN 5480  
W 40 x 2 x 30 x 18 x 9 g  
pressure maxi : 350 bar For M 125 only.

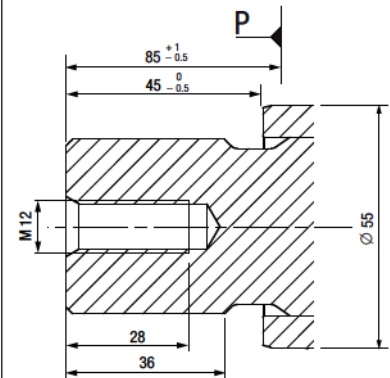

**D2** Cylindrical keyed shaft  $\varnothing 40$  DIN 6885  
AS 12 x 8 x 56 - For M 108R only.

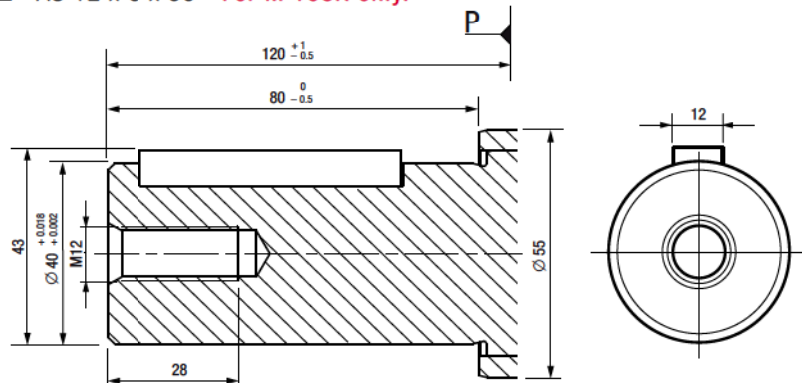

## Orifices d'alimentation

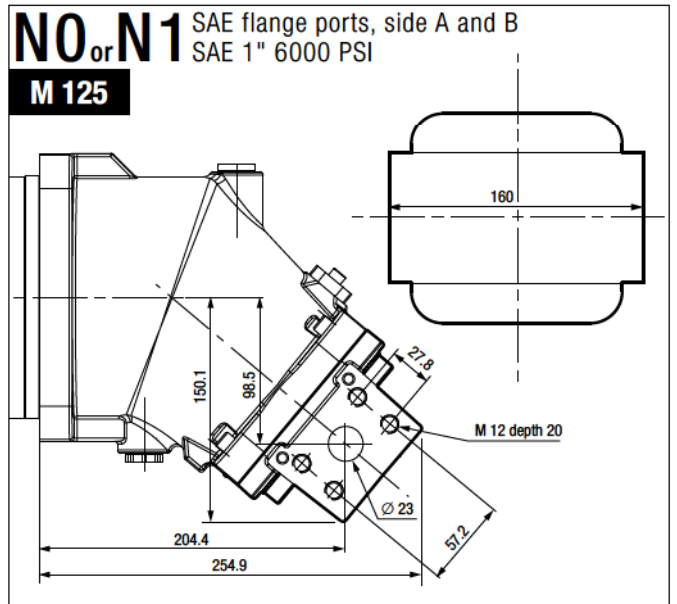
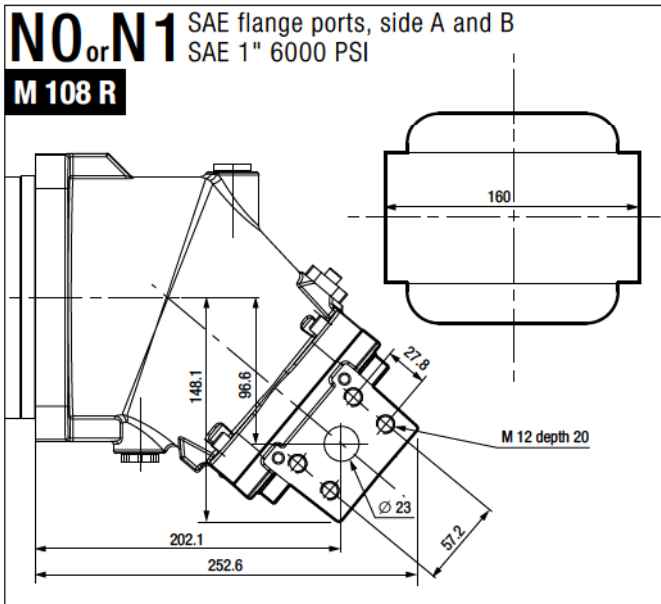
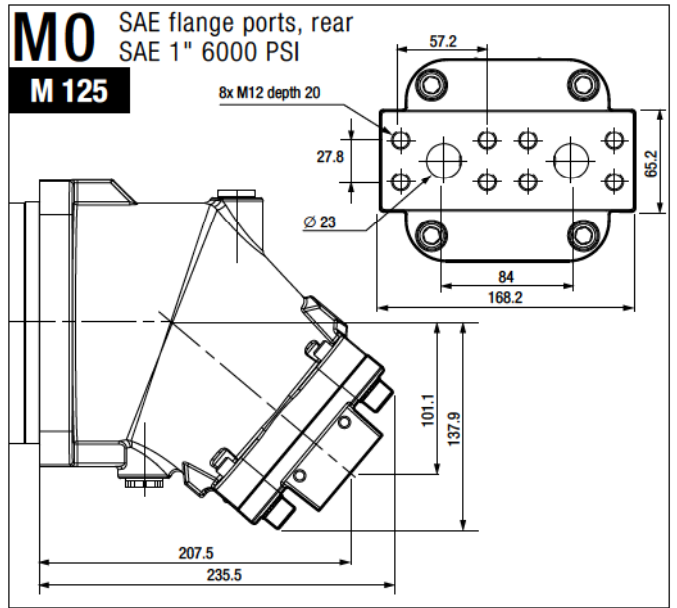
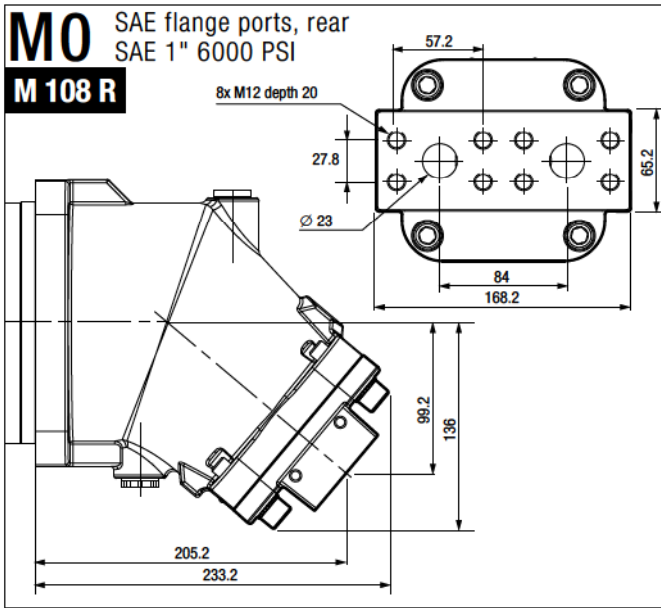
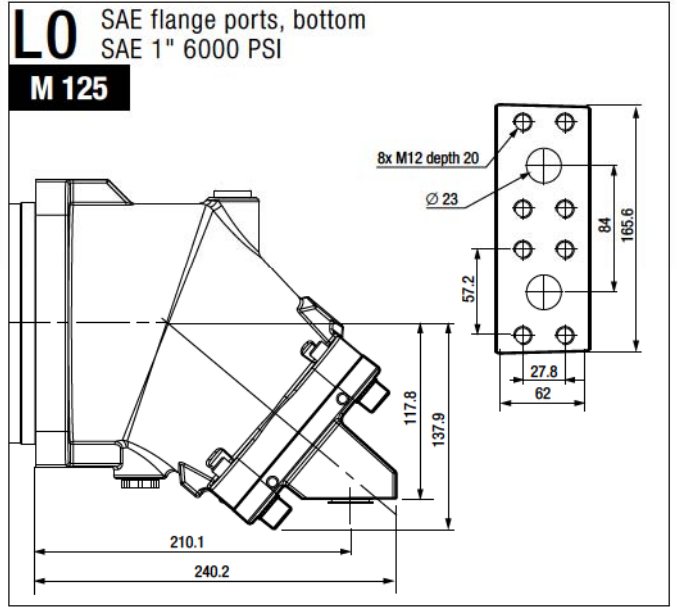
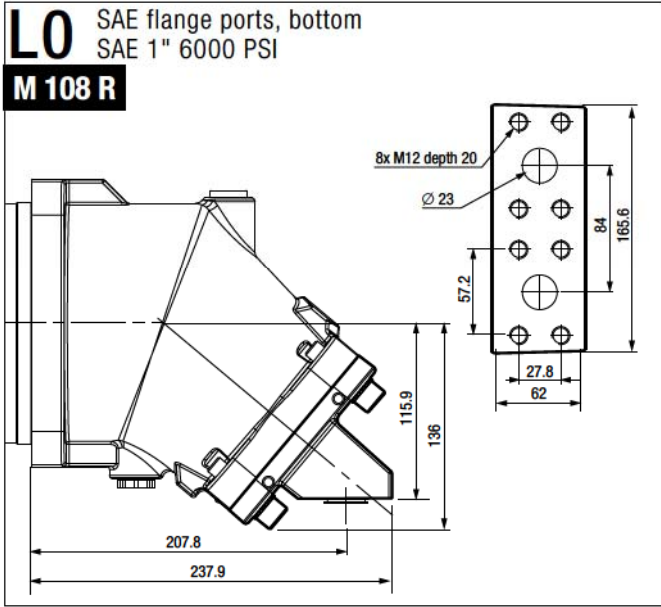

## Flushing and resupply valve

Used to create flow to cool the motor. This valve is essential for all intensive uses of motors and contributes to long service life, particularly in closed loop transmission applications.

The valve takes some hydraulic fluid internally from the return connection port (low pressure) and reinjects it into the motor housing. This is then evacuated via the motor drain line.

**The flushing and resupply valve is only available for use on motors with side ports (N1 or Q1 in order code).**

HYDRO LEDUC reference: VBS 091180.

### Schematic:

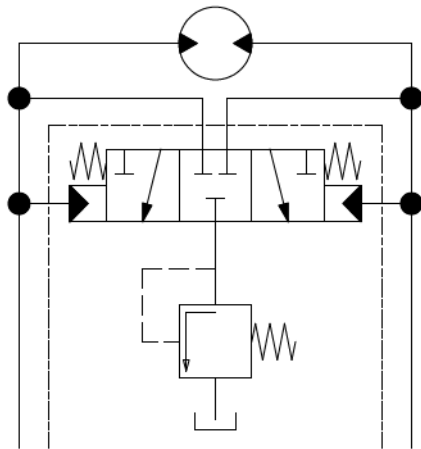

### Dimensions:

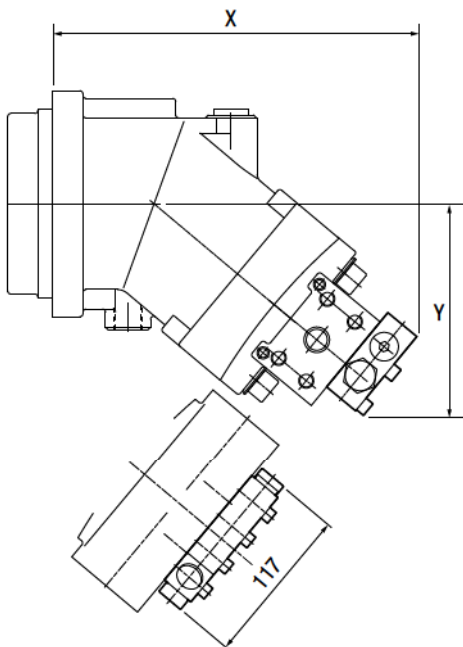

Motor model	X	Y
M 32 - 41	213	121
M 45 - 50 - 63	235	137
M 80 - 90 - 108	265	153
M 108R	273	153
M 125	275	155

Dimensions are given only as an indication.

## Speed sensor

The M series motors can be fitted with an induction type speed sensor, to measure rotating speed and also direction of rotation.

This accessory may only be used on motors which are suitably adapted to take it (see order code system on page 6, parameter no. 7).

HYDRO LEDUC reference: 093327.

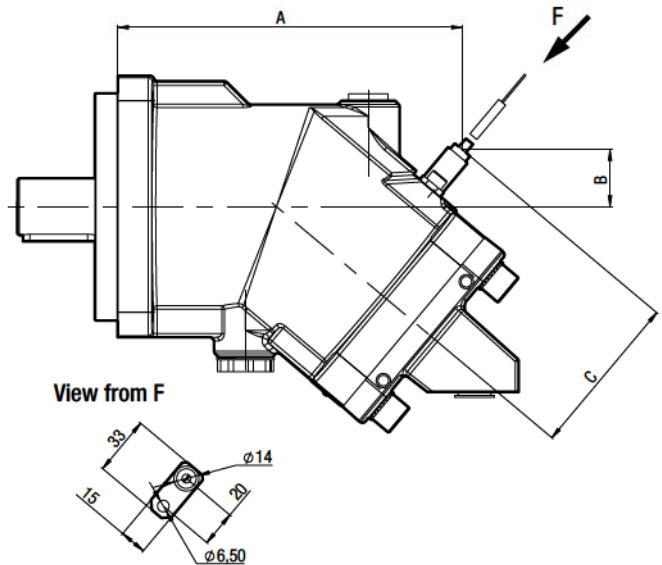

Motor model	A	B	C	Sensor number of teeth*
M 12 - 18	152	33	88	30
M 25	169	32	91	33
M 32 - 41	174	28	91	33
M 45 - 50 - 63	192	24	98	39
M 80 - 90 - 108	218	18	103	44
M 108R - 125	214	35	108	48

Note: maximum tightening torque = 10 m.N (7 lbf ft)

For further information, please contact us.

\* The M motors suitable for use with a speed sensor are fitted with a gear wheel on the barrel. When this barrel rotates, it produces a signal proportional to rotating speed, and which is picked up by the sensor.

### Technical data for the sensor:

Supply voltage**	5...32 V DC
Current consumption	maximum 6 mA without load
Output frequency	0 Hz... 20 kHz
Protection type	IP 69 k
Operating temperature	- 40°C...+ 125°C
Weight	around 65 g

\*\* Sensors for different supply voltage available on request.



■ LEDUC motors can be certified ATEX; please consult us.



1

2

3

4

- 1 Dimensional control of M motor housing
- 2 Assembly of M motor
- 3 Spline cutting (shaft)
- 4 M motors

# Installation and start-up M series motors

## Maximizing service life of bearings

In cases where there is a radial force on motor shaft, keeping the direction of that force within the shaded areas shown below will improve service life of the motor.

For acceptable radial and axial forces, see page 4.

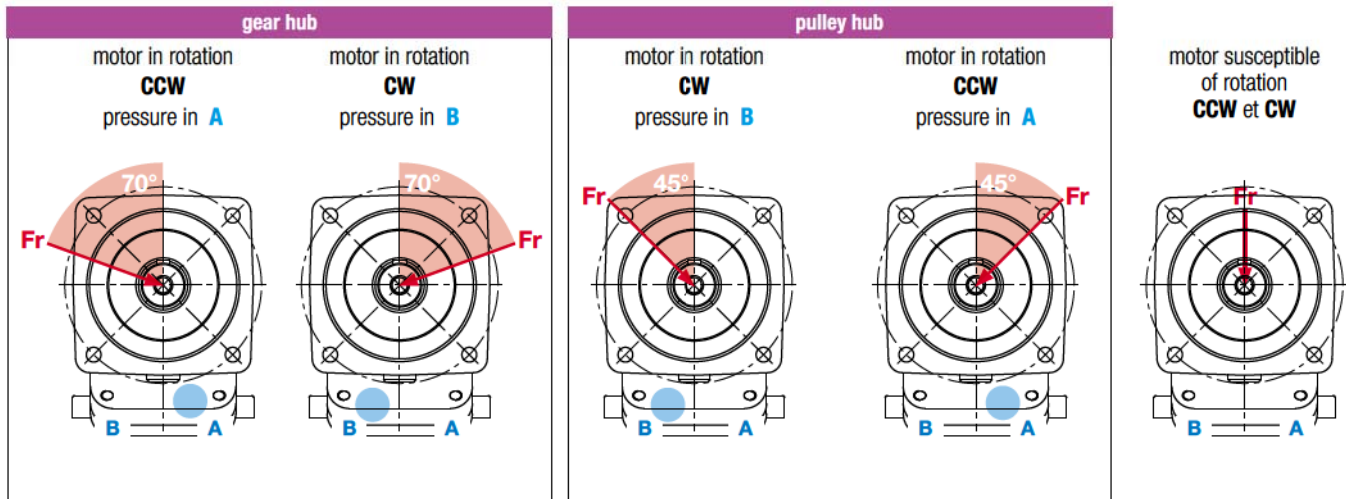

## Mounting position of motors

LEDUC motors can be used in any position.

In position «shaft upwards», make sure that the motor housing is completely filled with fluid. Bleed the air by the T3 connection.

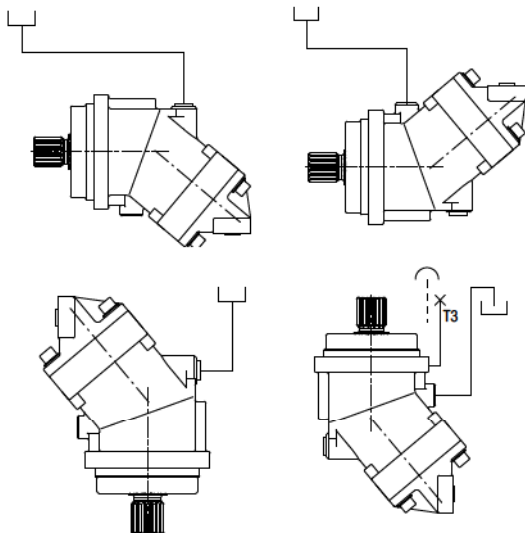

In installations where the position of the motor (H) is above the tank for the drain return, be sure the drain line is always submerged in fluid. If this is not the case, it is necessary to add a check valve on the drain line following the figure below.

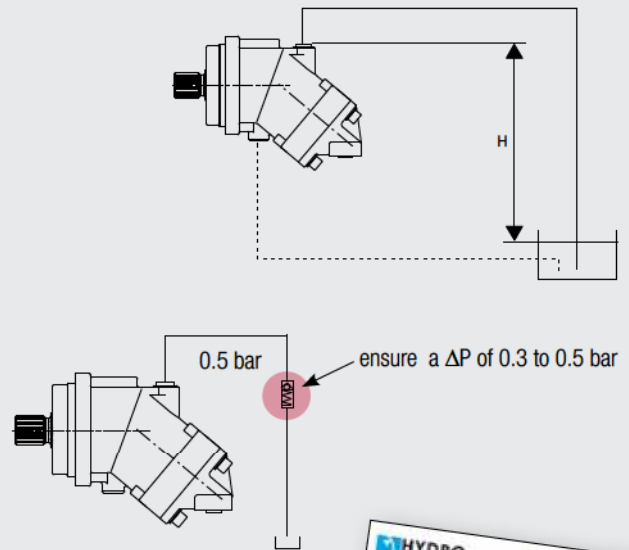

## Operating conditions

See page 2.

## Instructions for use

Each motor is supplied with an instruction leaflet, also available via e-mail on request [mail@hydroleduc.com](mailto:mail@hydroleduc.com).

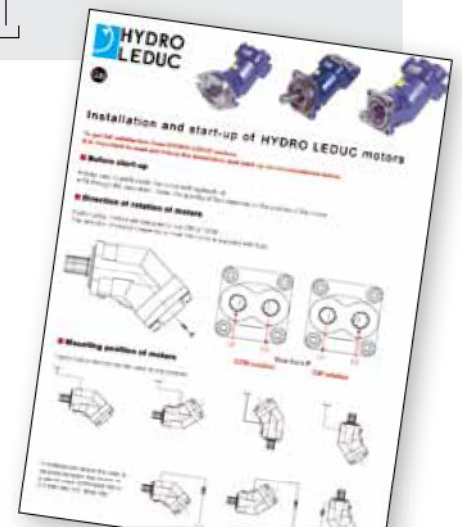



## other product lines

### hydraulic motors

Fixed displacement bent-axis pistons motors. Models from 12 to 126 cc. Available both in ISO and SAE versions.

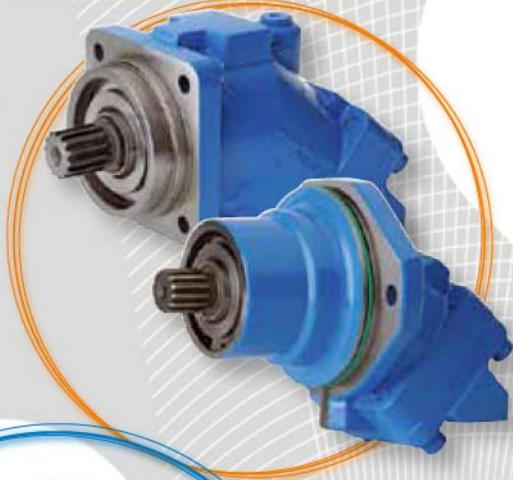

### mobile and industrial pumps

Fixed displacement pumps, the W series, and variable displacement pumps, the DELTA series. High pressure capabilities within minimal size.

**W** series: flanges to ISO 3019/2, shafts to DIN 5480.  
**DELTA** series: SAE shafts and flanges.



### hydro-pneumatic accumulators

Bladder, diaphragm accumulators. Spherical and cylindrical accumulators. Volume capacities from 20 cc to 50 liters. Pressures up to 500 bar. Accessories for use with hydraulic accumulators.

TXV

XP

PA  
PAC  
PAD

### piston pumps for trucks

HYDRO LEDUC offers 3 types of piston pumps perfectly suited to all truck and PTO-mount applications. Fixed and variable displacement from 12 to 150 cc.

### micro-hydraulics

This is a field of exceptional HYDRO LEDUC know-how:

- axial and radial piston pumps, of fixed and variable displacement,
- axial piston micro-hydraulic motors,
- micro-hydraulic units incorporating pump, electric motors, valving, controls, etc.

To users of hydraulic components which have to be housed in extremely small spaces, HYDRO LEDUC offers complete, original and reliable solutions for even the most difficult environments.



**we are passionate about hydraulics...**

**HYDRO LEDUC**

A dedicated R&D team means HYDRO LEDUC is able to adapt or create products to meet specific customer requirements. Working in close cooperation with the decision-making teams of its customers, HYDRO LEDUC optimizes proposals based on the specifications submitted.



a passion for hydraulics

**HYDRO LEDUC**

Head Office & Factory  
BP 9 - F-54122 AZERAILLES (FRANCE)  
Tél. +33 (0)3 83 76 77 40  
Fax +33 (0)3 83 75 21 58

**HYDRO LEDUC GmbH**

Haselwander Str. 5  
D-77746 SCHUTTERWALD (DEUTSCHLAND)  
Tel. +49 (0) 781-9482590  
Fax +49 (0) 781-9482592

**HYDRO LEDUC N.A., Inc.**

19416 Park Row - Suite 170  
HOUSTON, TEXAS 77084 (USA)  
Tel. +1 281 679 9654  
Fax +1 832 321 3553



Complete catalogues available at:  
[www.hydroleduc.com](http://www.hydroleduc.com)



**HYDRO LEDUC**

SAS with capital of 4 065 000 euros

Siret 319 027 421 00019

RC Nancy B 319 027 421

[mail@hydroleduc.com](mailto:mail@hydroleduc.com)

